

# AMC532

## Altera Carrier for FMC, Stratix® V (5SGXEA)



AMC532

## Key Features

- Single module, mid-size or full-size
- AMC FPGA based on Altera Stratix® V (5SGXEA) in F1932 package
- VITA 57.1 FMC HPC Connector (compatible with LPC)
- AMC Ports 0-15, 17-20 and FMC Ports DP0-9 are routed for high speed SERDES protocols
- All FMC LA, HA, HB pairs routed bi-directionally
- High-speed SERDES protocols such as PCIe x4, SRIO, XAUI, 1000Base-X are FPGA programmable
- Onboard PLL for buffering/multiplying and jitter cleaner (Stratum-3)
- M-LVDS/LVDS Clock crossbar switch for flexible clock routing
- 4 GB of DDR3 memory to FPGA (4 channels x 1 GB each)
- Serial Over LAN (SOL) with hardware RNG

## Benefits

- All FMC DP lanes, LA/HA/HB pairs, and clocks are routed from the FMC to the FPGA, providing great flexibility in FMC selection and capabilities
- Electrical, mechanical, software, and system-level expertise in house
- Full system supply from industry leader
- AS9100 and ISO9001 certified company



**vadatech**  
THE POWER OF VISION

**AdvancedMC™**



# AMC532

The AMC532 is an FPGA based on the Altera Stratix® V 5SGXEA and is compliant to AMC.1, AMC.2, AMC.3 and/or AMC.4 specifications.

The onboard, re-configurable FPGA interfaces directly to the AMC backplane, FMC connectors and four banks of DDR3 memory (32-bit wide per bank). This allows for large buffer sizes to be stored during processing as well as for queuing the data to the host.

The unit includes a sophisticated Quad PLL and M-LVDS/LVDS Cross Bar Switch (CBS) for low-jitter/low-latency clock handling with maximum flexibility between the backplane, FMC, and FPGA. The PLL has an option for Stratum-3 holdover.

AMC532 has Serial over LAN (SOL) per the IPMI specification and a hardware Random Number Generator (RNG) for secure session to redirect the console serial port of an FPGA-based soft-core CPU.

The AMC532 supports a wide range of VadaTech FMCs that include: FMC102, FMC103, FMC104, FMC105, FMC106, FMC107, FMC108, FMC109, FMC210, FMC211, FMC218, FMC219, FMC225 and FMC226.

See [Intel FPGA Solutions](#) for the advantages of using VadaTech products during application development.



Figure 1: AMC532

# Block Diagram

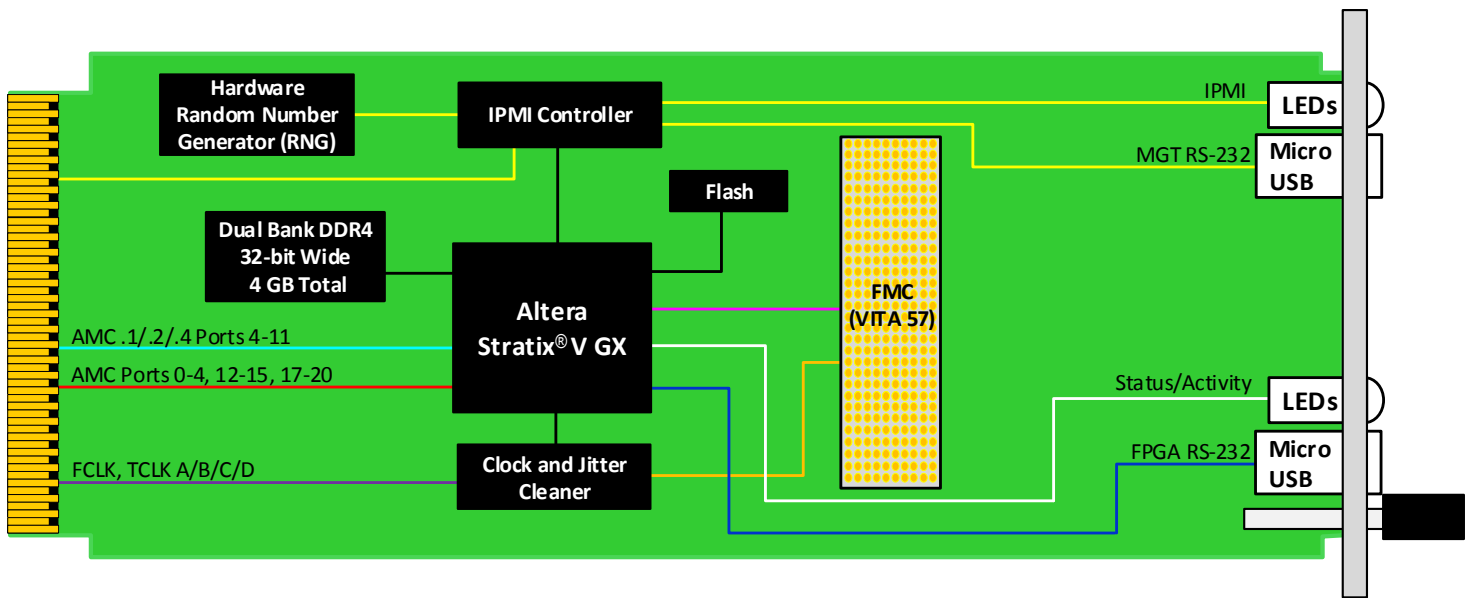

Figure 2: AMC532 Functional Block Diagram

# Front Panel

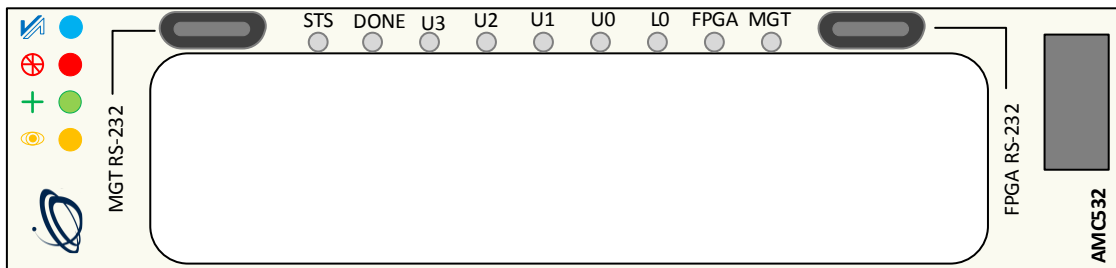

Figure 3: AMC532 Front Panel

# Reference Design

VadaTech provides an extensive range of FPGA-based products. The FPGA products are in two categories; FPGA boards with FMC carriers and FPGA products with high speed ADC and DACs. The FPGA products are designed in various architectures such as AMC modules, PCIe cards and Open VPX.

VadaTech provides a reference design implementation for our FPGAs complete with VHDL source code, documentation and configuration binaries. The reference design focuses on the I/O ring of the FPGA to demonstrate low-level operation of the interconnections between the FPGA and other circuits on the board and/or backplane. It is designed to prove out the hardware for early prototyping, engineering/factory diagnostics and customer acceptance of the hardware, but it does not strive to implement a particular end application. The reference VHDL reduces customer time to develop custom applications, as the code can be easily adapted to meet customer's application requirements.

The reference design allows you to test and validate the following functionality (where supported by the hardware):

- Base and Fabric channels
- Clocks
- Data transfers
- Memory
- User defined LEDs

VadaTech provides reference VHDL for testing basic hardware functionality. The reference VHDL is provided royalty free to use and modify on VadaTech products, so can be used within applications at no additional cost. However, customers are restricted from redistributing the reference code and from use of this code for any other purpose (e.g. it should not be used on non-VadaTech hardware).

The reference VHDL is shipped in one or more files based on a number of ordering options. Not all ordering options have an impact on the FPGA and a new FPGA image is created for those options that have direct impact on the FPGA. Use the correct reference image to test your hardware. For more information, refer to the FPGA reference design manual for your device which can be accessed from the customer support site along with the reference images.

## Supported Software

- Default FPGA image stored in flash memory
- Linux BSP
- Build Scripts
- Device Driver
- Reference application projects for other ordering options

The user may need to develop their own FPGA code or adapt VadaTech reference code to meet their application requirements. The supplied pre-compiled images may make use of hardware evaluation licenses, where necessary, instead of full licenses. This is because VadaTech does not provide licenses for the development tools or silicon vendor IP cores, so please contact FPGA vendor where these are required.

# Specifications

Architecture		
<b>Physical</b>	<b>Dimensions</b>	Single module, mid-size or full-size Width: 2.89" (73.5 mm) Depth 7.11" (180.6 mm)
<b>Type</b>	<b>AMC FPGA</b>	Altera FPGA Stratix® V GX
<b>Memory</b>		Four banks of DDR3 (32-bit wide)
Standards		
<b>AMC</b>	<b>Type</b>	AMC.0, AMC.1, AMC.2, AMC.3 and AMC.4 (FPGA programmable)
<b>Module Management</b>	<b>IPMI</b>	IPMI v2.0
<b>PCIe</b>	<b>Lanes</b>	Dual x4 via FPGA to AMC
<b>SRIO</b>	<b>Lanes</b>	Dual x4 via FPGA to AMC
<b>Ethernet</b>	<b>GbE and 10GbE</b>	Dual 10GbE (XAUI) and Dual 1000Base-BX to AMC
Configuration		
<b>Power</b>	<b>AMC532</b>	~30W (without mezzanine) application specific
<b>Environmental</b>	<b>Temperature</b>	See <a href="#">Ordering Options</a> and <a href="#">Environmental Spec Sheet</a> Storage Temperature: -40° to +90°C
	<b>Vibration</b>	Operating 9.8 m/s <sup>2</sup> (1G), 5 to 500 Hz on each axis
	<b>Shock</b>	30G each axis
	<b>Relative Humidity</b>	5 to 95% non-condensing
<b>Front Panel</b>	<b>Interface Connectors</b>	Dual micro USB for MGT RS-232 and FPGA RS-232 Single FMC slot
	<b>LEDs</b>	IPMI management control Four user defined LEDs
	<b>Mechanical</b>	Hot-swap ejector handle
<b>Software Support</b>	<b>Operating System</b>	N/A
Other		
<b>MTBF</b>		MIL Hand book 217-F@ TBD hrs
<b>Certifications</b>		Designed to meet FCC, CE and UL certifications, where applicable
<b>Standards</b>		VadaTech is certified to both the ISO9001:2015 and AS9100D standards
<b>Warranty</b>		Two (2) years, see <a href="#">VadaTech Terms and Conditions</a>

## INTEGRATION SERVICES AND APPLICATION-READY PLATFORMS

VadaTech has a full ecosystem of OpenVPX, ATCA and MTCA products including chassis platforms, shelf managers, AMC modules, Switch and Payload Boards, Rear Transition Modules (RTMs), Power Modules, and more. The company also offers integration services as well as pre-configured Application-Ready Platforms. Please contact VadaTech Sales for more information.

# Ordering Options

## AMC532 – A0C-DEF-0HJ

<b>A = FPGA PCIe Option</b> 0 = No PCIe 1 = PCIe on Ports 4-7 (single x4) 2 = PCIe on Ports 8-11 (single x4) 3 = PCIe on Ports 4-11 (Dual x4)	<b>D = FPGA Density</b> 0 = Reserved 1 = 5SGXA5 2 = 5SGXA7 (recommended default) 3 = 5SGXA9 4 = 5SGXAB	
	<b>E = FPGA Speed</b> 1 = Low 2 = High (recommended default)	<b>H = Temperature Range</b> 0 = Commercial (–5° to +55°C) 1 = Industrial (–20° to +70°C)
<b>C = Front Panel Size</b> 1 = Reserved 2 = Mid-size 3 = Full-size	<b>F = Clock Holdover Stability</b> 0 = Standard XO 1 = Stratum-3 (TCXO)	<b>J = Conformal Coating</b> 0 = No coating 1 = Humiseal 1A33 Polyurethane 2 = Humiseal 1B31 Acrylic

**Notes:**  
 For operational reasons VadaTech reserves the right to supply a higher speed FPGA device than specified on any particular order/delivery at no additional cost, unless the customer has entered into a Revision Lock agreement with respect to this product.

## Related Products

AMC713



- PrAMC with NXP QorIQ P5010/P5020
- Up to 16 GB DDR3 with ECC
- PCIe Gen2 on Ports 4-7 and 8-11 per AMC.1

FMC219



- FPGA Mezzanine Card (FMC) per VITA 57
- Dual DAC 14-bit @ 2.5 GSPS (AD9739)
- 2 Vpp differential analog output swing

VT899



- MTCA System Platform 5" x 7U x 9" deep (with handles 10" deep)
- Up to six AMCs: 6 full-size single-width or 3 full-size double width
- High-speed routing on 26 layers

# Contact

## VadaTech Corporate Office

198 N. Gibson Road, Henderson, NV 89014

Phone: +1 702 896-3337 | Fax: +1 702 896-0332

## Asia Pacific Sales Office

7 Floor, No. 2, Wenhua Street, Neihu District, Taipei 114, Taiwan

Phone: +886-2-2627-7655 | Fax: +886-2-2627-7792

## VadaTech European Sales Office

VadaTech House, Bulls Copse Road, Southampton, SO40 9LR

Phone: +44 2380 016403

[info@vadatech.com](mailto:info@vadatech.com) | [www.vadatech.com](http://www.vadatech.com)

# Choose VadaTech

## We are technology leaders

- First-to-market silicon
- Constant innovation
- Open systems expertise

## We commit to our customers

- Partnerships power innovation
- Collaborative approach
- Mutual success

## We deliver complexity

- Complete signal chain
- System management
- Configurable solutions

## We manufacture in-house

- Agile production
- Accelerated deployment
- AS9100 accredited



**vadatech**  
THE POWER OF VISION

## Trademarks and Disclaimer

The VadaTech logo is a registered trademark of VadaTech, Inc. Other registered trademarks are the property of their respective owners. AdvancedTCA™ and the AdvancedMC™ logo are trademarks of the PCI Industrial Computers Manufacturers Group. All rights reserved. Specification subject to change without notice.

© 2020 VadaTech Incorporated. All rights reserved.  
DOC NO. 4FM737-12 REV 01 | VERSION 3.4 – FEB/20