

VPX760

Intel® Xeon® Processor E-2176M
or E-2276ME VPX 3U



VPX760

Key Features

- 3U VPX Processor Intel® Xeon® Processor E-2176M or E-2276ME (Coffee Lake)
- PCIe Gen3 x8 (bifurcated as dual x4) and PCIe Gen2 x4
- Dual GbE Ports and Dual SATA on P1
- PCIe Gen3 x8 (bifurcated as dual x4) on P2
- Front-panel video and dual USB 3.0 connectors
- Dual Display Port and dual USB 3.0 on P2
- 32 GB of DDR4 with ECC and 64 GB of Flash
- TPM (Trusted Platform Management)
- Health Management through dedicated Processor

Benefits

- High performance Xeon® Processor E-2176M or E-2276ME with CM246 PCH
- Availability of chassis supporting 40G-capable backplanes
- Design utilizes proven VadaTech subcomponents and engineering techniques
- Electrical, mechanical, software, and system-level expertise in house
- Full system supply from industry leader
- RoHS compliant, AS9100 and ISO9001 certified company

OpenVPX™



vadatech
THE POWER OF VISION



VPX760

The VPX760 is a processor module (VITA 46) for general purpose processing in demanding applications. Based on the Intel® Xeon® Processor E-2176M or E-2276ME (Coffee Lake) with CM246 PCH. The processor base frequency is 2.7 GHz with max turbo frequency of 4.4 GHz.

The unit provides PCIe Gen3 x8 (bifurcated as dual x4), PCIe Gen2 x4, dual GbE and Dual SATA Gen3 on P1. There is PCIe Gen3 x8 (bifurcated as dual x4), dual Display Port and dual USB3.0 on P2.

It also provides GbE via RJ45, video via mini display and dual USB3.0 type C connectors for extended storage or peripherals on the front panel. Additional video display output and dual USB3.0 are also routed to P2.

The VPX760 has up to 32 GB of DDR4 memory with ECC and 64 GB of Flash for OS. The BIOS allows booting from onboard NAND, offboard SATA, PXE boot as well as USB.

The module provides TPM (Trust Management Platform) for secure boot.

Linux OS is standard on the VPX760, consult VadaTech for other options.

The unit is available in a range of temperature and shock/vib specifications per ANSI/VITA 47, up to V3 and OS2.



Figure 1: VPX760

Block Diagram

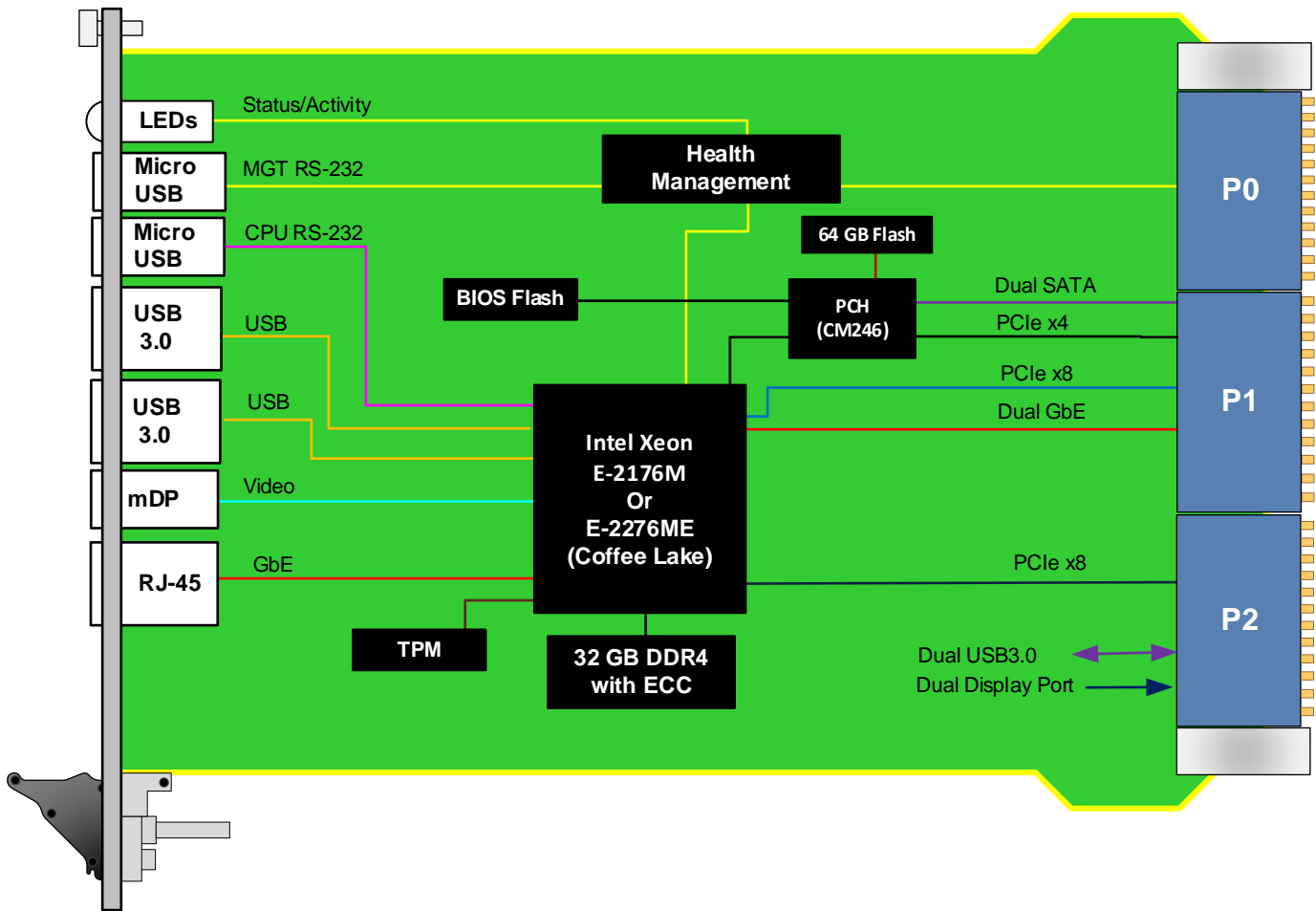

Figure 2: VPX760 Functional Block Diagram

Front Panel



Figure 3: VPX760 Front Panel

Pinout Block Diagram

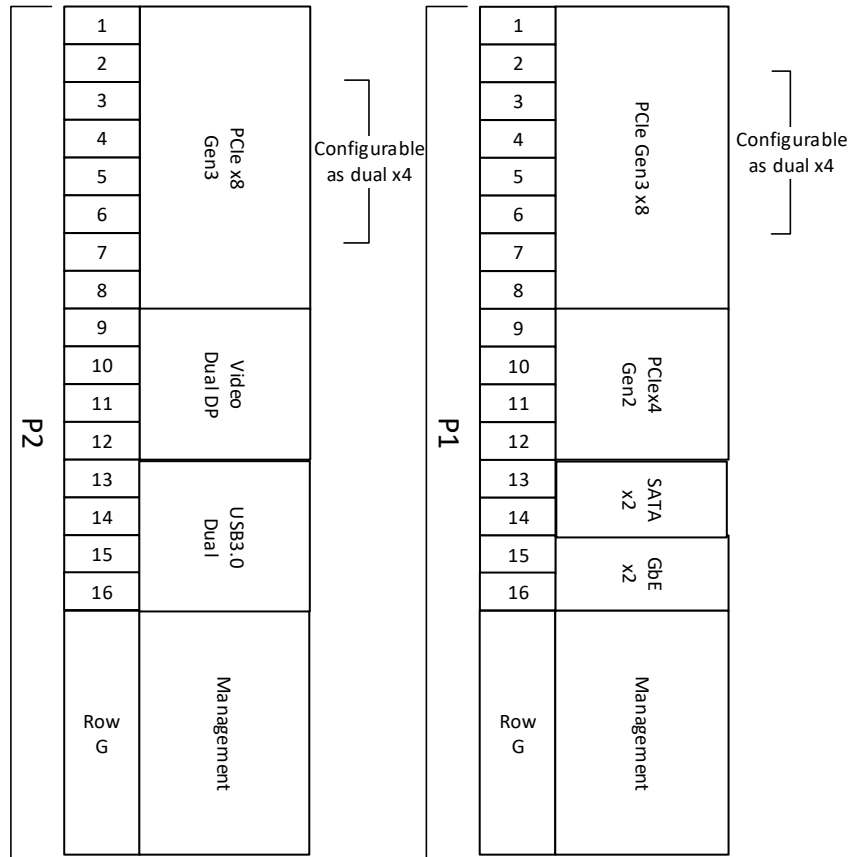

Figure 4: VPX760 Pinout Block Diagram

Specifications

Architecture	
Physical	Dimensions 3U, 1" pitch
Configuration	
Power	VPX761 ~58W
Processor	CPU Intel® Xeon® Processor E-2176M or E-2276ME
	Memory DDR4 32GB with ECC
	Storage BIOS NAND Flash 64GB Flash
PCIe Gen3	Lanes Dual x8 on P1/P2 and single Gen2 x4 on P1
Platform Control Hub (PCH)	CM246
VPX Interfaces	Slot Profiles See Ordering Options
	Payload Profile See Figure 3
	Power Supplies On P0: +12V; +5V and +3.3V
Front Panel	Interface Connectors 1x RJ-45 for GbE 2x USB type C connectors for USB 3.0 2x Micro USB for IPMI RS-232 and PCH RS-232 1x Mini Display Port for graphics
	LEDs IPMI, activity and user defined
Software Support	Operating System Linux default, contact Sales for VxWorks and Windows support requirements
Other	
MTBF	MIL Hand book 217-F@ TBD hrs
Certifications	Designed to meet FCC, CE and UL certifications, where applicable
Standards	VadaTech is certified to both the ISO9001:2015 and AS9100D standards
Warranty	Two (2) years, see VadaTech Terms and Conditions

INTEGRATION SERVICES AND APPLICATION-READY PLATFORMS

VadaTech has a full ecosystem of OpenVPX, ATCA and MTCA products including chassis platforms, shelf managers, AMC modules, Switch and Payload Boards, Rear Transition Modules (RTMs), Power Modules, and more. The company also offers integration services as well as pre-configured Application-Ready Platforms. Please contact VadaTech Sales for more information.

Ordering Options

VPX760 – ABC-D00-GHJ

A = DDR4 Memory 0 = Reserved 1 = 16 GB 2 = 32 GB	D = CPU 0 = E-2176M 1 = E-2276ME 2 = Reserved	G = Applicable Slot Profiles 0 = 5HP, VITA 48.1 1 = 5HP, IEEE
B = Flash Storage 0 = Reserved 1 = 64 GB		H = Environmental See Environmental Specification
C = VPX Connector Type 0 = Standard 50u Gold Rugged 1 = KVPX Connectors		J = Conformal Coating 0 = No coating 1 = Humiseal 1A33 Polyurethane 2 = Humiseal 1B31 Acrylic

Environmental Specification

Option H	Air Cooled			Conduction Cooled		
	H = 0	H = 1	H = 2	H = 3	H = 4	
Operating Temperature	AC1* (0°C to +55°C)	AC3* (-40°C to +70°C)	CC1* (0°C to +55°C)	CC3* (-40°C to +70°C)	CC4* (-40°C to +85°C)	
Storage Temperature	C1* (-40°C to +85°C)	C3* (-50°C to +100°C)	C1* (-40°C to +85°C)	C3* (-50°C to +100°C)	C3* (-50°C to +100°C)	
Operating Vibration	V2* (0.04 g2/Hz max)	V2* (0.04 g2/Hz max)	V3* (0.1 g2/Hz max)	V3* (0.1 g2/Hz max)	V3 (0.1 g2/Hz max)	
Storage Vibration	OS1* (20g)	OS1* (20g)	OS2* (40g)	OS2* (40g)	OS2* (40g)	
Humidity	95% non-condensing	95% non-condensing	95% non-condensing	95% non-condensing	95% non-condensing	

Notes:

*Nomenclature per ANSI/VITA 47. Contact local sales office for conduction cooled (H = 2, 3, 4).

Related Products

VPX516



- 3U FPGA carrier for FPGA Mezzanine Card (FMC) per VITA 46 and VITA 57
- Xilinx Virtex-7 690T FPGA in FFG-1761 package
- High-performance clock jitter cleaner

VPX592



- 3U FPGA carrier for FMC per VITA 46 and VITA 57
- Xilinx Kintex UltraScale™ XCKU115 FPGA
- High-performance clock jitter cleaner

VPX599



- Xilinx Kintex UltraScale™ XCKU115 FPGA
- Dual ADC 12-bit @ 6.4 GSPS
- Dual DAC 16-bit @ 12 GSPS (AD9162 or AD9164)

Contact

VadaTech Corporate Office

198 N. Gibson Road, Henderson, NV 89014

Phone: +1 702 896-3337 | Fax: +1 702 896-0332

Asia Pacific Sales Office

7 Floor, No. 2, Wenhua Street, Neihu District, Taipei 114, Taiwan

Phone: +886-2-2627-7655 | Fax: +886-2-2627-7792

VadaTech European Sales Office

VadaTech House, Bulls Copse Road, Southampton, SO40 9LR

Phone: +44 2380 016403

info@vadatech.com | www.vadatech.com

Choose VadaTech

We are technology leaders

- First-to-market silicon
- Constant innovation
- Open systems expertise

We commit to our customers

- Partnerships power innovation
- Collaborative approach
- Mutual success

We deliver complexity

- Complete signal chain
- System management
- Configurable solutions

We manufacture in-house

- Agile production
- Accelerated deployment
- AS9100 accredited



vadatech
THE POWER OF VISION

Trademarks and Disclaimer

The VadaTech logo is a registered trademark of VadaTech, Inc. Other registered trademarks are the property of their respective owners. AdvancedTCA™ and the AdvancedMC™ logo are trademarks of the PCI Industrial Computers Manufacturers Group. All rights reserved. Specification subject to change without notice.

© 2020 VadaTech Incorporated. All rights reserved.
DOC NO. 4FM737-12 REV 01 | VERSION 1.5 – SEP/23