

VT806

1U MTCA.4 Chassis with 2 AMC Slots, Intel® Xeon™ W-11865MRE (Tiger Lake-H) and PCIe Gen3

VT806

Key Features

- MicroTCA.4 low-profile chassis platform, 19" x 1U x 14.2" deep
- Integrated Intel Xeon W-11865MRE (Tiger Lake-H) 11th-Generation (8 core with Turbo 4.7 GHz)
- 64GB of DDR4 with ECC
- Dual M.2 NVMe socket
- Supports two MTCA.4 mid-size or one full-size double module
- Optional mounting to convert slots to support two MTCA.0 mid-size or one full-size single module
- Integrated MCH, Power Module and Cooling unit
- Front panel GbE/10GbE, JTAG, USB 3.2, 2x DP and RS-232
- Dual PCIe Gen 3 x4 or single x8 to each AMC
- Layer 3 managed GbE switch
- Removable Air Filter, Power Module, and Fan Tray

Benefits

- High performance density with integrated MCH and Xeon 11th Generation processor in a compact 1U size
- Ideal chassis development platform with 2 AMC slots
- Electrical, mechanical, software, and system-level expertise in house
- AS9100 and ISO9001 certified company
- Full system supply from industry leader

μTCA®



vadatech
THE POWER OF VISION



VT806

The VT806 chassis offers two AMC slots (and corresponding RTMs), an integrated MCH, and an integrated Intel Xeon W-11865MRE (Tiger Lake-H) 11th-Generation (8 core with Turbo speed of 4.7 GHz), power and cooling.

The double module AMC slots conform to MTCA.4 specification for applications that require rear I/O and signal conditioning, including High Energy Physics, video processing, defense, and network security.

There are dual x4 or single x8 PCIe Gen3 lanes from the processor to each AMC. The two AMC slots are point-to-point routed between the two AMCs on higher ports.

Linux OS is standard on the VT806, consult VadaTech for other options.

This VadaTech product is suitable to support [High Energy Physics](#) data processing applications.

Removable Power Supplies

The VT806 has a removable 400W AC or 460W DC power supply located on the rear of the chassis.

Integrated MCH, GbE Switch and Processor

The unit has integrated MCH, Cooling Unit (CU), Power Module (PM) and Processor. The MCH is based on VadaTech UTC056 with integrated Intel Xeon W-11865MRE (Tiger Lake-H) 11th-Generation (8 core with Turbo 4.7 GHz). The module provides PCIe Gen3 to each slot. The processor comes with the Trusted Platform Management (TPM).

The on-board managed layer two switch connects the two AMC GbE (port 0/1) to the CPU GbE as well as front-panel dual 10GbE.

The CPU comes with 64 GB of DDR4 memory with ECC, and two M2. NVMe sockets and 64GB of Flash. The BIOS allows booting from the USB, NVMe, on board Flash or PXE boot from the Ethernet ports. The chassis front panel provides dual DP, dual USB3.2, 10GbE copper and RS-232 from the CPU.

GPS and General-Purpose Clocks

The VT806 has an option for the most sophisticated clock distribution in the market including GPS and general-purpose clocking features to meet the most stringent requirements such as wireless infrastructure and high speed A/D. The unit provides MTCA.4-compliant low-jitter/low-skew backplane crossbar clock routing matrix for CLK1/CLK2/CLK3 for all AMCs, IEEE1588/SyncE, and NTP clocking plus other functions.

JTAG Switch Module (JSM)

The VT806 has option for JSM which supports virtual probe for JTAG over Ethernet.

Cooling and Temperature Sensors

The VT806 has an intelligent Cooling Unit with airflow from right to left. The removable air filter is hot-swappable for ease of maintenance and has a dedicated optical sensor for the MCH to detect its presence after replacement. Temperature sensors in the chassis monitor the intake and the outtake air temperature throughout the unit.

Figure 1: VT806 Front View

Figure 2: VT806 Rear View

Block Diagram

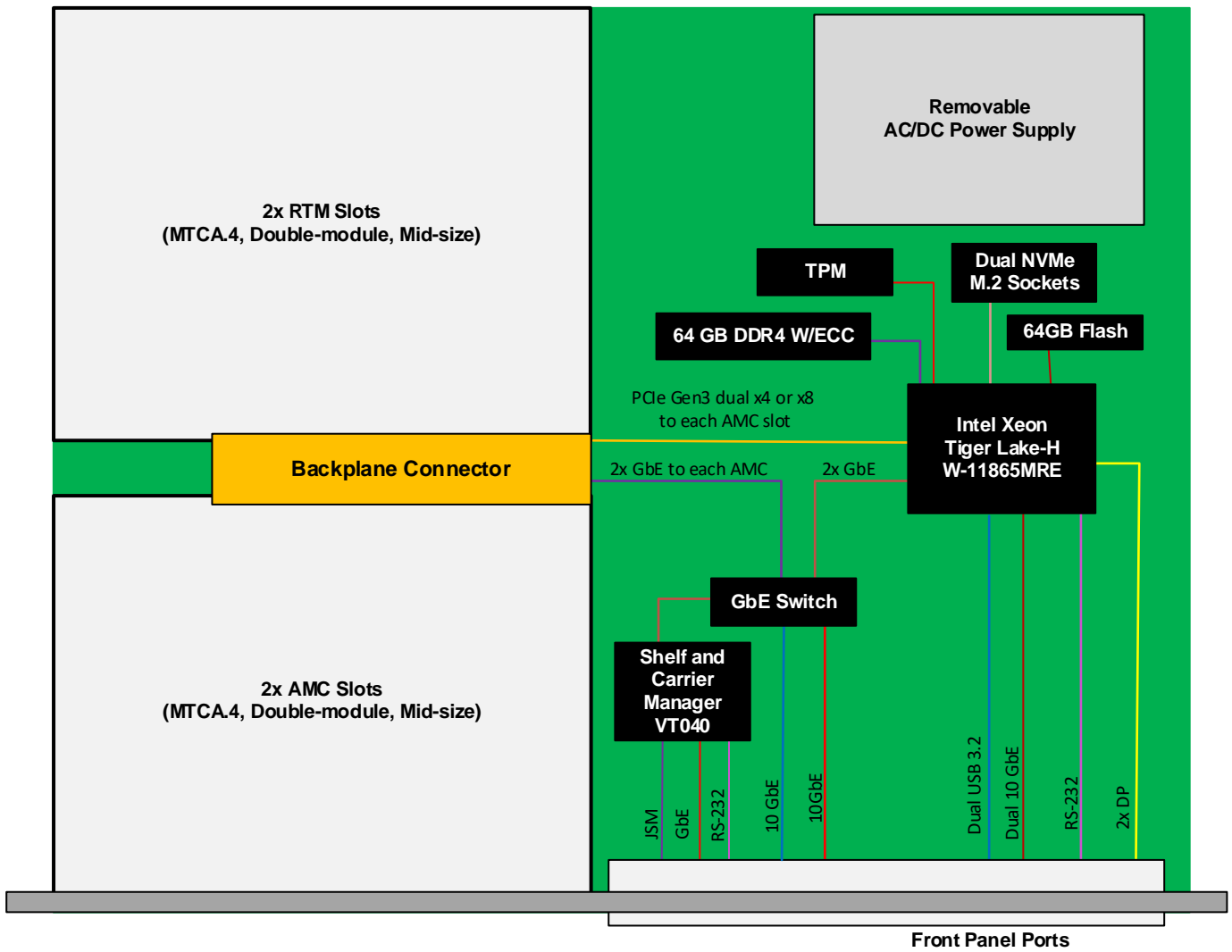

Figure 3: VT806 Block Diagram

Backplane Connections

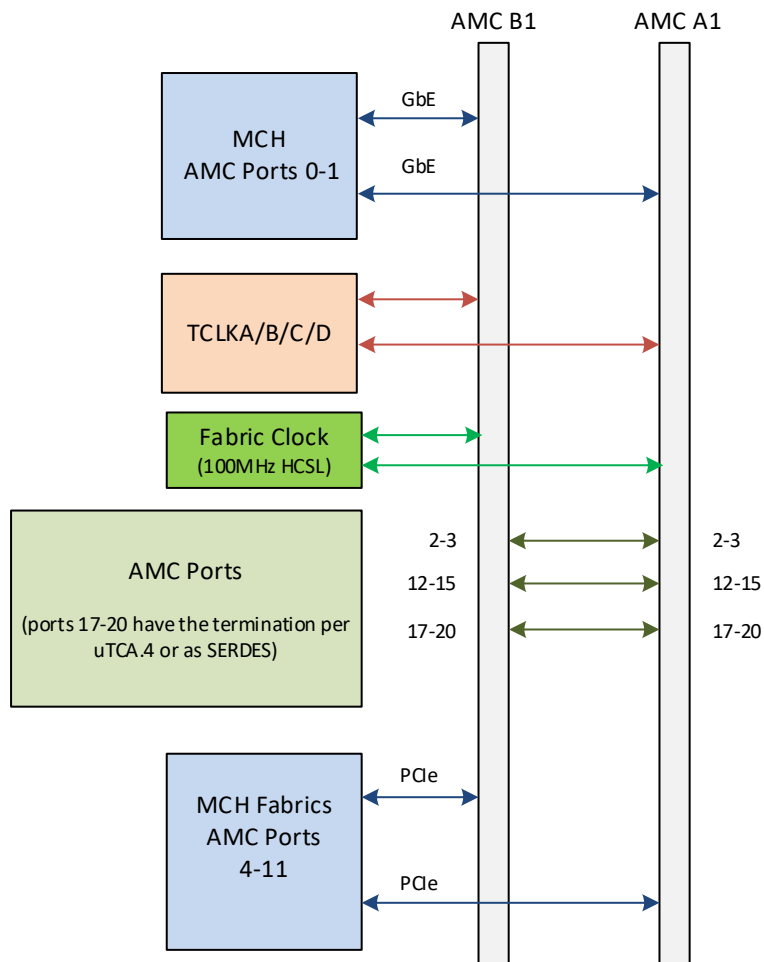

Figure 4: VT806 Backplane Connections

Specifications

Architecture	
Physical	Dimensions Width: 19"
	Depth: 14.2"
	Height: 1U
Type	MTCA Chassis 2 MTCA.4 Slots with RTMs (per option C)
Standards	
AMC	Type AMC.0, AMC.1, AMC.2 and AMC.3
MTCA	Type MTC.4, Single MCH, Single Power Module and Intelligent Cooling Unit
Configuration	
Power	VT806 400W AC or 460W DC -36 to -75V
	90-264V AC with frequency from 47-63 Hz or -36 to -75V DC
Environmental	Temperature See Ordering Options
	Storage Temperature: -40° to +85°C
	Altitude 10,000 ft operating 40,000 ft non-operating
	Relative Humidity 5 to 95% non-condensing
Cooling	Right to left
Other	
MTBF	MIL Hand book 217-F@ TBD hrs
Certifications	Designed to meet FCC, CE and UL certifications, where applicable
Standards	VadaTech is certified to both the ISO9001:2015 and AS9100D standards
Warranty	One (1) year, see VadaTech Terms and Conditions

INTEGRATION SERVICES AND APPLICATION-READY PLATFORMS

VadaTech has a full ecosystem of OpenVPX, ATCA and MTCA products including chassis platforms, shelf managers, AMC modules, Switch and Payload Boards, Rear Transition Modules (RTMs), Power Modules, and more. The company also offers integration services as well as pre-configured Application-Ready Platforms. Please contact VadaTech Sales for more information.

Ordering Options

VT806 – ABC-DEF-00J

A = Power Supply 0 = AC (400W) 1 = DC -36 to -75V (460W)	D = Ports 17-20 0 = per MTCA.4 as bussed MLVDS 1 = SERDES (point to point) between the modules	
B = M.2 NVMe 0 = No NVMe Drive 1 = Dual 2TB each (4TB Total) 2 = Dual 4TB each (8TB total) 3 = Dual 8TB each (16TB total) 4 = Reserved	E = Front Panel (FP) Clocking 0 = No FP clocking (Backplane clocking only) 1 = Dual LVCMOS Clock In/Out 2 = Sine Wave In + LVCMOS In/Out 3 = Built-in GPS receiver + LVCMOS In/Out 4 = Dual Sine Wave In 5 = GPS receiver + Sine Wave In 6 = Sine Wave In (up to 17dBm) +TTL/LVCMOS In	
C = Module Slot Size * 0 = Dual double module mid-size slots 1 = One full-size double module slot (slot A1 not used) 3 = Dual single module mid-size slots 4 = One full-size single module slot (slot A1 not used)	F = JTAG Switch Module (JSM) 0 = None 1 = JSM	J = Temperature Range and Coating 0 = Commercial, No coating 1 = Commercial, Humiseal 1A33 Polyurethane 2 = Commercial, Humiseal 1B31 Acrylic 3 = Industrial, No coating 4 = Industrial, Humiseal 1A33 Polyurethane 5 = Industrial, Humiseal 1B31 Acrylic

Notes: * options 0 and 1 can host MTCA.4 modules with RTM. Options 3 and 4 can host only MTCA.0 modules without RTM.

Related Products

AMC523



- Dual DAC 16-bit @ 250 MSPS,
- Xilinx Kintex-7 FPGA
- Acceleration Development Package DAQ Series™ with EPICS support

AMC580



- Xilinx Zynq UltraScale+ MPSoC XCZU19EG FPGA
- Zone 3 class D1.2 connector pinout per DESY specification
- Dual FMC sites

MZ523C



- Mezzanine for MRT523, 12 optical detectors routed to mezzanine connector
- Per channel programmable gain, bandwidth and AC/DC coupling
- Acceleration Development Package DAQ Series™ with EPICS support

Contact

VadaTech Corporate Office

198 N. Gibson Road, Henderson, NV 89014

Phone: +1 702 896-3337 | Fax: +1 702 896-0332

Asia Pacific Sales Office

7F-3, No16, Jihu Rd Lane 35, Neihu District, Taipei 114, Taiwan

Phone: +886-2-2627-7655 | Fax: +886-2-2627-7792

VadaTech European Sales Office

VadaTech House, Bulls Copse Road, Southampton, SO40 9LR

Phone: +44 2380 016403

info@vadatech.com | www.vadatech.com

Choose VadaTech

We are technology leaders

- First-to-market silicon
- Constant innovation
- Open systems expertise

We commit to our customers

- Partnerships power innovation
- Collaborative approach
- Mutual success

We deliver complexity

- Complete signal chain
- System management
- Configurable solutions

We manufacture in-house

- Agile production
- Accelerated deployment
- AS9100 accredited



vadatech
THE POWER OF VISION

Trademarks and Disclaimer

The VadaTech logo is a registered trademark of VadaTech, Inc. Other registered trademarks are the property of their respective owners. AdvancedTCA™ and the AdvancedMC™ logo are trademarks of the PCI Industrial Computers Manufacturers Group. All rights reserved. Specification subject to change without notice.

© 2020 VadaTech Incorporated. All rights reserved.
DOC NO. 4FM737-12 REV 01 | VERSION 1.0 – FEB/23