

VPX589

Dual ADC @ 6.4 GSPS and
Dual DAC @ 12 GSPS,
Virtex UltraScale+™, 3U VPX



VPX589

Key Features

- Xilinx Virtex UltraScale+™ XCVU13P FPGA
- Dual ADC 12-bit @ 6.4 GSPS or quad ADC at 3.2 GSPS with TI ADC12DJ3200
- Option for ADC12DJ3200 or ADC12DJ2700
- Dual DAC 16-bit @ 12 GSPS (AD9162 or AD9164)
- 16 SERDES as PCIe/SRIO/10GbE/40GbE/Aurora to P1
- 8 SERDES as PCIe/SRIO/10GbE/40GbE/Aurora to P2
- Clock Jitter cleaner
- Option for Direct RF Clock sampling for the ADC/DAC
- Single bank of DDR4 64-bit wide 8 GB Total
- Health Management through dedicated Processor

Benefits

- RADAR data processing
- Reference design with VHDL source code speeds application development
- Full system supply from industry leader
- AS9100 and ISO9001 certified company

OpenVPX™



vadatech
THE POWER OF VISION



VPX589

The VPX589 provides dual ADC sampling rates of up to 6.4 GSPS at a 12-bit resolution (TI ADC12DJ3200 or ADC12DJ2700) or quad inputs at 3.2 GSPS. Also, dual DAC delivers update rates of up to 12 GSPS and incorporates direct RF synthesis capable of 6 GSPS at a 16-bit resolution (Analog Devices AD9162 or AD9164). This makes VPX589 suitable for signal capture/analysis applications such as COMINT/SIGINT, radar, research and instrumentation.

The unit has an onboard Virtex UltraScale+™ XCVU13P FPGA that directly interface with ADC/DAC and a bank of 64-bit wide DDR4 memory channels with a total of 8 GB memory.

The module routes x16 SERDES to P1 which can run any protocol (i.e PCIe/SRIO/10G/40G/Aurora) and x8 SERDES with 16 LVDS signals to P2.

The unit is available in a range of temperature and shock/vib specifications per ANSI/VITA 47, up to V3 and OS2.

Please contact VadaTech for details of Conduction Cooled versions.



Figure 1: VPX589

Block Diagram

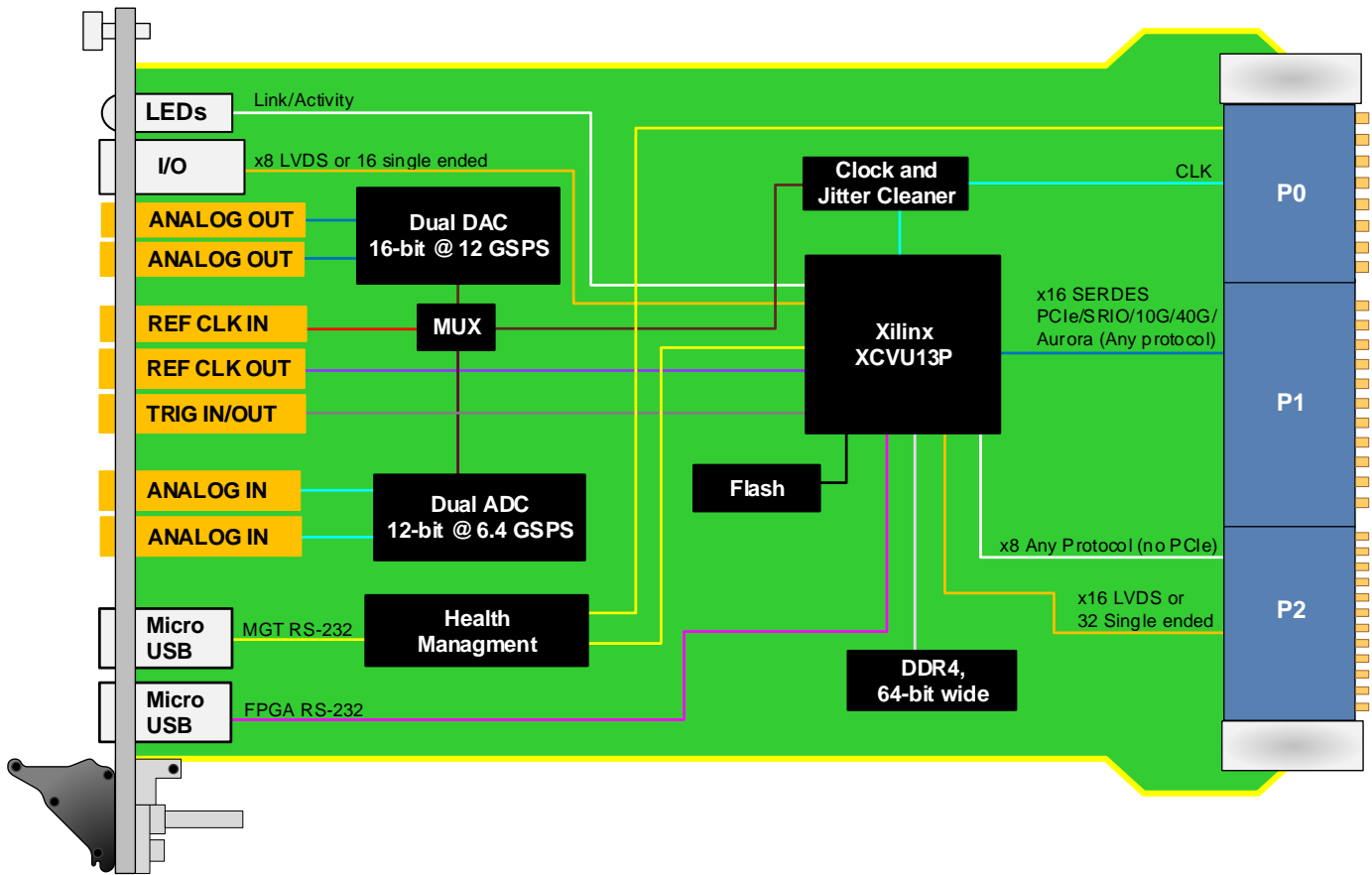

Figure 2: VPX589 Functional Block Diagram

Reference Design

VadaTech provides an extensive range of Xilinx based FPGA products. The FPGA products are in two categories; FPGA boards with FMC carriers and FPGA products with high speed ADC and DACs. The FPGA products are designed in various architectures such as AMC modules, PCIe cards and Open VPX.

VadaTech provides a reference design implementation for our FPGAs complete with VHDL source code, documentation and configuration binaries. The reference design focuses on the I/O ring of the FPGA to demonstrate low-level operation of the interconnections between the FPGA and other circuits on the board and/or backplane. It is designed to prove out the hardware for early prototyping, engineering/factory diagnostics and customer acceptance of the hardware, but it does not strive to implement a particular end application. The reference VHDL reduces customer time to develop custom applications, as the code can be easily adapted to meet customer's application requirements.

The reference design allows you to test and validate the following functionality (where supported by the hardware):

- Base and Fabric channels
- Clocks
- Data transfers
- Memory
- User defined LEDs

Xilinx provides Vivado Design Suite for developing applications on Xilinx based FPGAs. VadaTech provides reference VHDL developed using the Vivado Design Suite for testing basic hardware functionality. The reference VHDL is provided royalty free to use and modify on VadaTech products, so can be used within applications at no additional cost. However, customers are restricted from redistributing the reference code and from use of this code for any other purpose (e.g. it should not be used on non-VadaTech hardware).

The reference VHDL is shipped in one or more files based on a number of ordering options. Not all ordering options have an impact on the FPGA and a new FPGA image is created for those options that have direct impact on the FPGA. Use the correct reference image to test your hardware. For more information, refer to the FPGA reference design manual for your device which can be accessed from the customer support site along with the reference images.

Supported Software

- Default FPGA image stored in flash memory
- Linux BSP
- Build Scripts
- Device Driver
- Reference application projects for other ordering options

The user may need to develop their own FPGA code or adapt VadaTech reference code to meet their application requirements. The supplied pre-compiled images may make use of hardware evaluation licenses, where necessary, instead of full licenses. This is because VadaTech does not provide licenses for the Vivado tool or Xilinx IP cores, so please contact Xilinx where these are required.

Xilinx also provides System Generator tools for developing Digital Signal Processing (DSP) applications.

See the following links:

[Xilinx Vivado Design Suite](#), [Xilinx System Generator for DSP](#).

Data Acquisition

VadaTech offers a wide range of FPGA AMCs, RTMs, FMC Carriers and FMCs that can be combined to build a Data Acquisition (DAQ) sub-system. The DAQ Series software, when used with a supported hardware configuration, provides all that is needed to configure the system, acquire data and transfer it to a host processor. It also includes a user-configurable Graphical User Interface (Figure 3), which incorporates real-time display of acquired data. The host can be within the MTCA system or, via PCI113 or PCI123, in a separate PC. Full documentation is provided to allow users to customize system behavior or develop their own application on the VPX/AMC/FMC hardware.

The DAQ includes data acquisition software that allows users to get up and running quickly and easily, while providing a high level of performance and allowing the user to extend functionality by adding their own FPGA code. Please contact VadaTech sales for the latest information on supported combinations of VadaTech hardware. (Note that the DAQ Series software is not currently supported for 3rd party hardware).

Components provided in the DAQ software include:

- System libraries to configure clocking and triggers
- Sequencer to configure the acquisition (duration, start, stop)
- High-performance DMA firmware for acquiring ADC outputs and transferring to host processor
- Linux driver for host processor (e.g. AMC72x)
- EPICS channel access client API
- Pre-configured GUI (based on Qt Creator)

This software set allows the user to acquire, transfer and display data without the need for any user programming of the hardware. Status information is included in the GUI display, to ease integration and debugging activity.

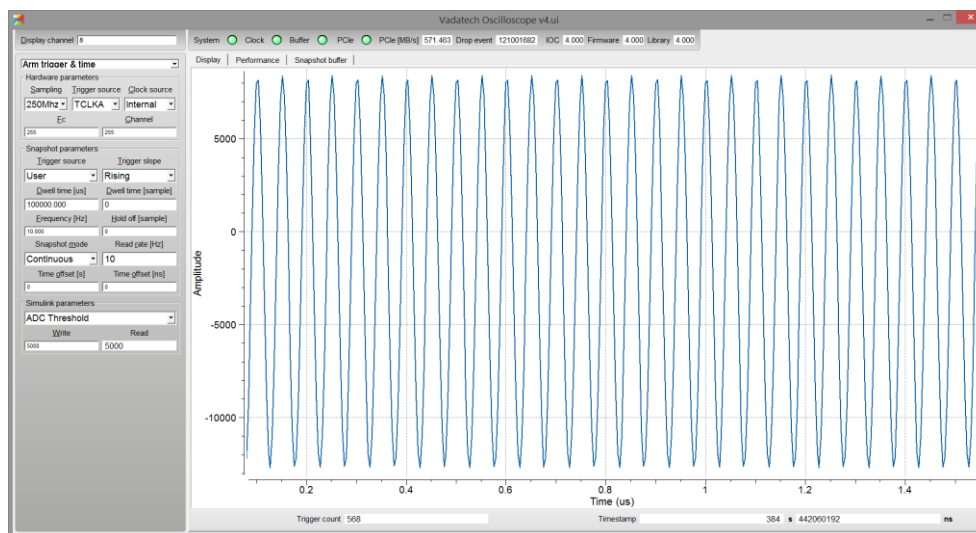

Figure 3: Typical Graphic User Interface Display

The data acquisition software provided as part of the DAQ can be used as-delivered without the user needing to develop any FPGA code.

Full source code is provided for the libraries, sequencer, DMA, Linux driver and GUI, allowing users to easily customize or brand to their own requirements at the exception of a low level PCIe IP from Xilinx provided only as Netlist (this low-level block doesn't require modification/customization from integrators or end-users).

Specifications

Architecture		
Physical	Dimensions	3U, 1" pitch
FPGA		Xilinx UltraScale+™ XCVU13P FPGA
Configuration		
Power	VPX589	~55W (dependent on FPGA load)
Front Panel	SMPM	11x SMPM
	Micro USB	RS-232 from Health Management CPU RS-232 from FPGA
	LEDs	8 User defined/Activity and Health Management
VPX Interfaces	Slot Profiles	See Ordering Options
	Rear IO	x16 SERDES could be configured as PCIe/SRIO/10GbE/40GbE/Aurora on P1 x8 SERDES could be configured as SRIO/10GbE/40GbE/Aurora on P2
		x16 LVDS or 32 single-ended on P2 RTM management on P1/P2
Other		
MTBF		MIL Hand book 217-F@ TBD hrs
Certifications		Designed to meet FCC, CE and UL certifications, where applicable
Standards		VadaTech is certified to both the ISO9001:2015 and AS9100D standards
Warranty		Two (2) years, see VadaTech Terms and Conditions

INTEGRATION SERVICES AND APPLICATION-READY PLATFORMS

VadaTech has a full ecosystem of OpenVPX, ATCA and MTCA products including chassis platforms, shelf managers, AMC modules, Switch and Payload Boards, Rear Transition Modules (RTMs), Power Modules, and more. The company also offers integration services as well as pre-configured Application-Ready Platforms. Please contact VadaTech Sales for more information.

Ordering Options

VPX589 – ABC-DEF-GHJ-K00

A = RF Direct Clock Sampling 0 = Direct RF Clock 1 = Onboard Wideband PLL	D = FPGA Speed 1 = High (-2)* 2 = High (-2LE) 3 = Highest (-3E)*	G = Applicable Slot Profiles 0 = 5 HP	K = VPX Connector Type 0 = Standard 50u Gold Rugged 1 = KVPX Connectors
B = DAC 0 = AD9162 1 = AD9164 2 = No DAC	E = Clock Holdover Stability 0 = Standard (XO) 1 = Stratum-3 (TCXO)	H = Environmental See Environmental Specification	
C = ADC 0 = ADC12DJ3200 1 = ADC12DJ2700 2 = Reserved	F = PCIe Option (P1)** 0 = No PCIe (40GbE, 10GbE, SRIO, etc.) 1 = x4 or x8 PCIe via FPGA 2 = Quad x4, or Dual x8 via FPGA	J = Conformal Coating 0 = No coating 1 = Humiseal 1A33 Polyurethane 2 = Humiseal 1B31 Acrylic	

Notes: *Minimum Order Quantity applies for these FPGA SKU's.

**When the ports are not PCIe the lanes are electrically compatible with SRIO, XAUI, and other SerDes protocols.

For operational reasons VadaTech reserves the right to supply a higher speed FPGA device than specified on any particular order/delivery at no additional cost, unless the customer has entered into a Revision Lock agreement with respect to this product.

Environmental Specification

Option H	Air Cooled		Conduction Cooled		
	H = 0	H = 1	H = 2	H = 3	H = 4
Operating Temperature	AC1* (0°C to +55°C)	AC3* (-40°C to +70°C)	CC1* (0°C to +55°C)	CC3* (-40°C to +70°C)	CC4* (-40°C to +85°C)
Storage Temperature	C1* (-40°C to +85°C)	C3* (-50°C to +100°C)	C1* (-40°C to +85°C)	C3* (-50°C to +100°C)	C3* (-50°C to +100°C)
Operating Vibration	V2* (0.04 g2/Hz max)	V2* (0.04 g2/Hz max)	V3* (0.1 g2/Hz max)	V3* (0.1 g2/Hz max)	V3 (0.1 g2/Hz max)
Storage Vibration	OS1* (20g)	OS1* (20g)	OS2* (40g)	OS2* (40g)	OS2* (40g)
Humidity	95% non-condensing	95% non-condensing	95% non-condensing	95% non-condensing	95% non-condensing

Notes: *Nomenclature per ANSI/VITA 47. Contact local sales office for conduction cooled (H = 2, 3, 4).

Related Products

VPX516



- 3U FPGA carrier for FPGA Mezzanine Card (FMC) per VITA 46 and VITA 57
- Xilinx Virtex-7 690T FPGA in FFG-1761 package
- High-performance clock jitter cleaner

VPX517



- 3U FPGA carrier for FMC per VITA 46 and VITA 57
- Xilinx Kintex-7 410T FPGA in FFG-900 package
- High-performance clock jitter cleaner

VPX592



- 3U FPGA carrier for FMC per VITA 46 and VITA 57
- Xilinx Kintex UltraScale™ XCKU115 FPGA
- High-performance clock jitter cleaner

Contact

VadaTech Corporate Office

198 N. Gibson Road, Henderson, NV 89014

Phone: +1 702 896-3337 | Fax: +1 702 896-0332

Asia Pacific Sales Office

7 Floor, No. 2, Wenhua Street, Neihu District, Taipei 114, Taiwan

Phone: +886-2-2627-7655 | Fax: +886-2-2627-7792

VadaTech European Sales Office

VadaTech House, Bulls Copse Road, Southampton, SO40 9LR

Phone: +44 2380 016403

info@vadatech.com | www.vadatech.com

Choose VadaTech

We are technology leaders

- First-to-market silicon
- Constant innovation
- Open systems expertise

We commit to our customers

- Partnerships power innovation
- Collaborative approach
- Mutual success

We deliver complexity

- Complete signal chain
- System management
- Configurable solutions

We manufacture in-house

- Agile production
- Accelerated deployment
- AS9100 accredited



Trademarks and Disclaimer

The VadaTech logo is a registered trademark of VadaTech, Inc. Other registered trademarks are the property of their respective owners. AdvancedTCA™ and the AdvancedMC™ logo are trademarks of the PCI Industrial Computers Manufacturers Group. All rights reserved. Specification subject to change without notice.

© 2019 VadaTech Incorporated. All rights reserved.

DOC NO. 4FM737-12 REV 01 | VERSION 1.3 – NOV/19



vadatech
THE POWER OF VISION